



PURCHASE & STORES SECTION

No. MANUU/Purchase/F.19/Vol.II/2013-14/Part-II/323

11th July 2016

To,

.....

Sub: MANUU - Purchase – Supply of furniture at Dept. of CS & IT – Limited Tender Enquiry – Reg.

* * * * *

Sir,

The University intends to procure furniture for Dept. of CS & IT as per the specifications mentioned below from the original manufacturer / authorized dealer only. You are requested to submit quotations in sealed envelope as per Annexure-I along with EMD of Rs.10,000/- in the form of DD on a printed letter head of the firm consisting the details as per attached proforma, on or before **02.08.2016** by 3.00 p.m. and the tender will be opened on the same day at 3:00 p.m. in the presence of prospective bidders.

Specification of furniture:

Sl.	Particulars	Qty. req.
1.	Table: 48” (w) 96” (L) 36” (H), Top: 18mm commercial ply with laminated and edges with 2mm PVC bidding Frame: 2” (14 guage) square pipe at top and legs (6 legs) (with rubber bushes) Horizontal 1.5” (14 guage) foot rest at all sides 6.5” from floor powder coated.	04
2.	Table: 96”x48”x36” Top: 18mm commercial ply with laminated and edges with 2mm PVC bidding Frame: 2” (14 guage) square pipe at top and legs (6 legs) (with rubber bushes) Horizontal 2” (14 guage) foot rest at all sides 6.5” from floor powder coated.	04
3.	Table: 24”x24”x36” Top: 18mm commercial ply with laminated and edges with 2mm PVC bidding Frame: 2” (14 guage) square pipe at top and legs (4 legs) (with rubber bushes) Horizontal 1” foot rest at all sides 3” from floor powder coated and another foot rest 18” from floor.	01
4.	Stool: 12”x12”x27” Top: 18mm commercial ply with laminated and edges with 2mm PVC bidding Frame: 1” guage square pipe top and legs / foot rest (4 legs) (with rubber bushes) Horizontal 1” foot rest at all sides 3” from floor and one side additional foot rest of 1” (14 guage) and 7” from floor, powder coated	26



PURCHASE & STORES SECTION

Terms & Conditions:

1. Price's are to be quoted both in figures and in words. In case of a discrepancy, that quoted in words/ lowest amount will be taken as valid.
2. The bidder should be a direct manufacturer or authorized dealer of the above items.
3. Incomplete Bids in any respect are liable to be rejected.
4. The bid must mention the specifications as per the **Annexure – I** and to submit the sample as required by the University.
5. The quantity included in the bid can be increased or decreased at the discretion of the Competent Authority, Maulana Azad National Urdu University Hyderabad.
6. The supply of said items has to be made within a period of two weeks from the date of receipt of P.O. 0.5% cost of the whole supply for every week as late supply will be deducted from the bill/EMD to the maximum of 10% after which the order will remain cancelled. In case, if the firm supplies inferior quality, the University may at its decision reject the entire material and impose penalty.
7. Item offered in the tender enquiry may be re-ordered at the same rate, terms & conditions within a period of twelve months/one year.
8. The amount quoted should include all the charges including taxes, transportation, etc.
9. All pages of the tender document are to be signed and stamped by the tendering firm and to be attached along with the bids.
10. Conditional bids are not accepted.
11. If any manufacturing defect is found till one year / warranty period from the date of supply, the firm should replace the part/item on their own cost within one week from the date of such complaint.
12. The University reserves all the rights to place the order items wise with the firm quoted L-1 rates.
13. The L-1 firms should submit 10% value of Purchase Order as Performance Guarantee in the form of D.D/Fixed Deposit (Joint Account) / Bank Guarantee in favour of MANUU which will be released after 60 days after fulfilling of all tender obligations.
14. For any query/clarification, you may contact Dept. of CS & IT.
15. The University reserves all the rights to reject or accept any tender without assigning any reason or cancel or withdraw the tender notice.
16. In case of any dispute, Hyderabad will be the Jurisdiction. The Registrar, Maulana Azad National Urdu University, Hyderabad shall decide the issue and his decision will be final and shall be binding on the both parties.

Sd/-

Assistant Registrar
(Purchase & Stores)



PURCHASE & STORES SECTION

Annexure-I

Sl.	Particulars	Qty. req.	Unit Price	Total (inclusive of all)
1.	Table: 48" (w) 96" (L) 36" (H), Top: 18mm commercial ply with laminated and edges with 2mm PVC bidding Frame: 2" (14 guage) square pipe at top and legs (6 legs) (with rubber bushes) Horizontal 1.5" (14 guage) foot rest at all sides 6.5" from floor powder coated.	04		
2.	Table: 96"x48"x36" Top: 18mm commercial ply with laminated and edges with 2mm PVC bidding Frame: 2" (14 guage) square pipe at top and legs (6 legs) (with rubber bushes) Horizontal 2" (14 guage) foot rest at all sides 6.5" from floor powder coated.	04		
3.	Table: 24"x24"x36" Top: 18mm commercial ply with laminated and edges with 2mm PVC bidding Frame: 2" (14 guage) square pipe at top and legs (4 legs) (with rubber bushes) Horizontal 1" foot rest at all sides 3" from floor powder coated and another foot rest 18" from floor.	01		
4.	Stool: 12"x12"x27" Top: 18mm commercial ply with laminated and edges with 2mm PVC bidding Frame: 1" guage square pipe top and legs / foot rest (4 legs) (with rubber bushes) Horizontal 1" foot rest at all sides 3" from floor and one side additional foot rest of 1" (14 guage) and 7" from floor, powder coated	26		

Place :

Date :2016

Signature of the authorized
representative of the firm with stamp

PURCHASE & STORES SECTION

MARKING TABLE

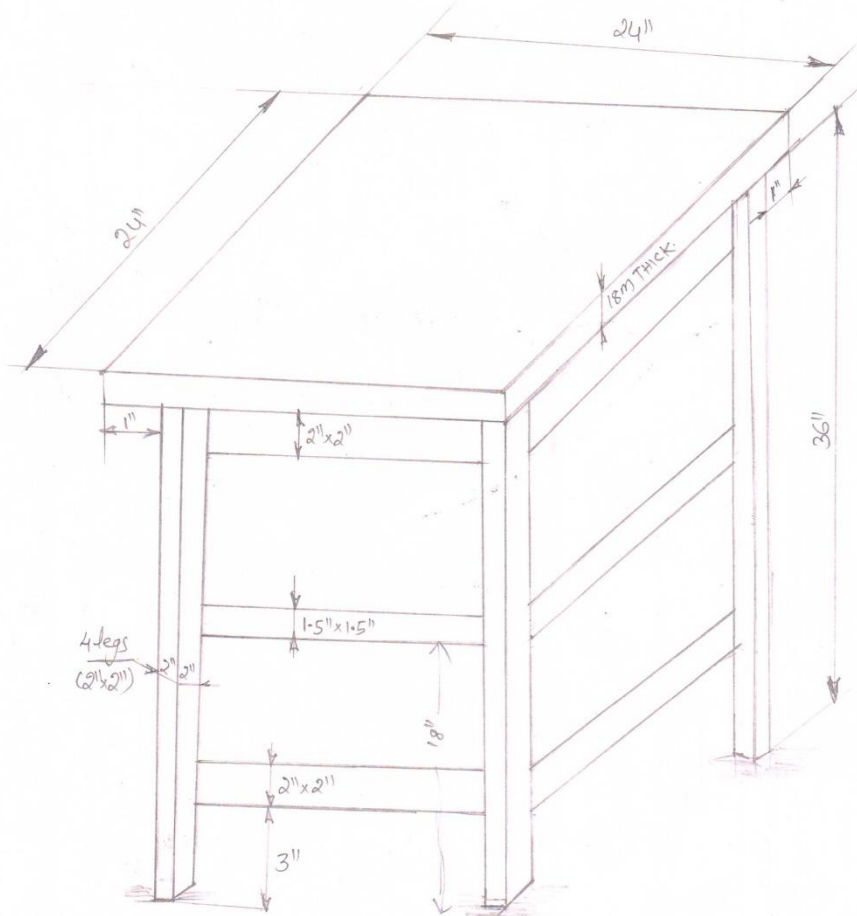

Marking Table Specification

- Hard plywood (waterproof) Size 24"x24"x18mm Thick.
- Height 36" Square pipe 2"x2"

27

PURCHASE & STORES SECTION

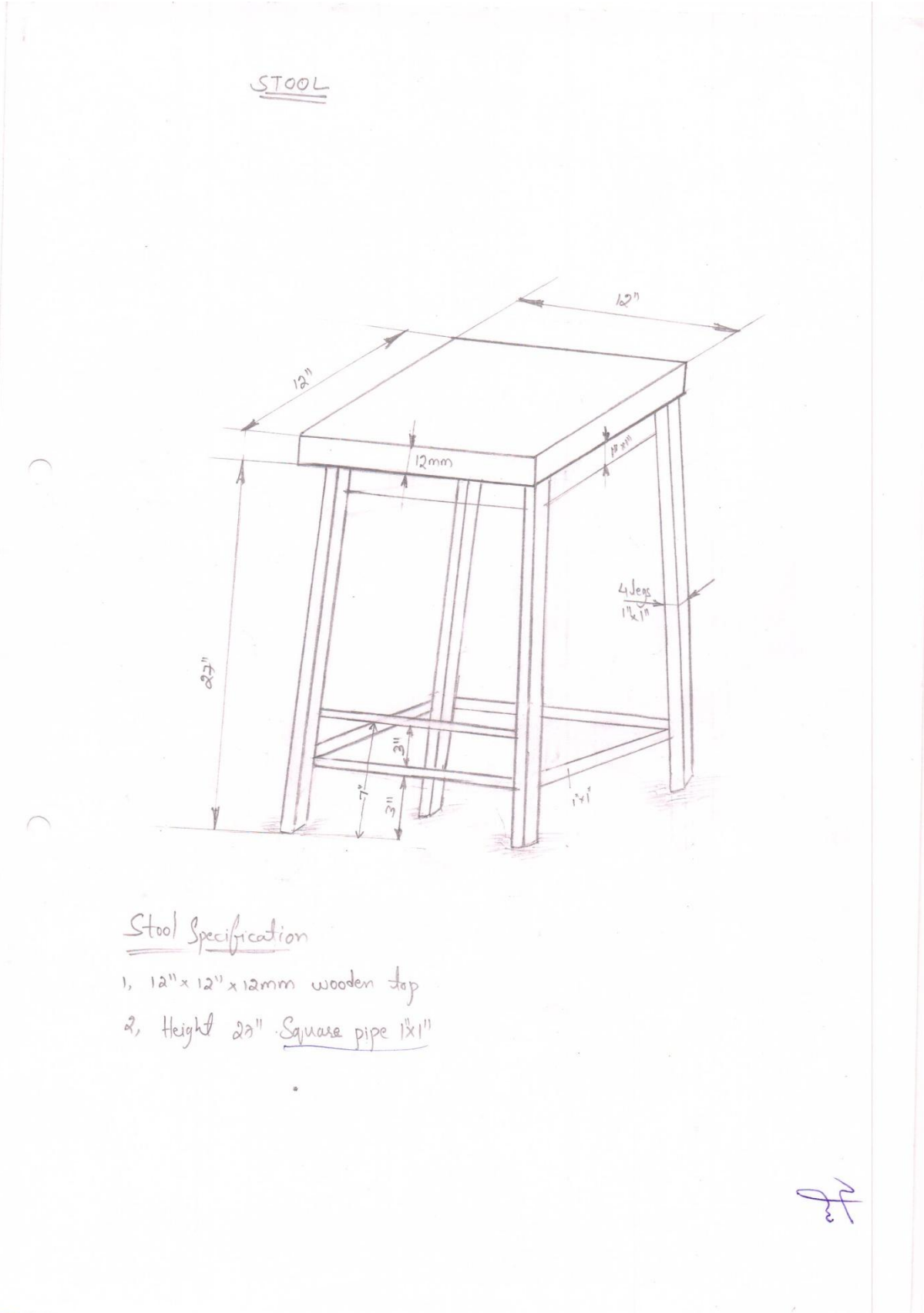

PURCHASE & STORES SECTION

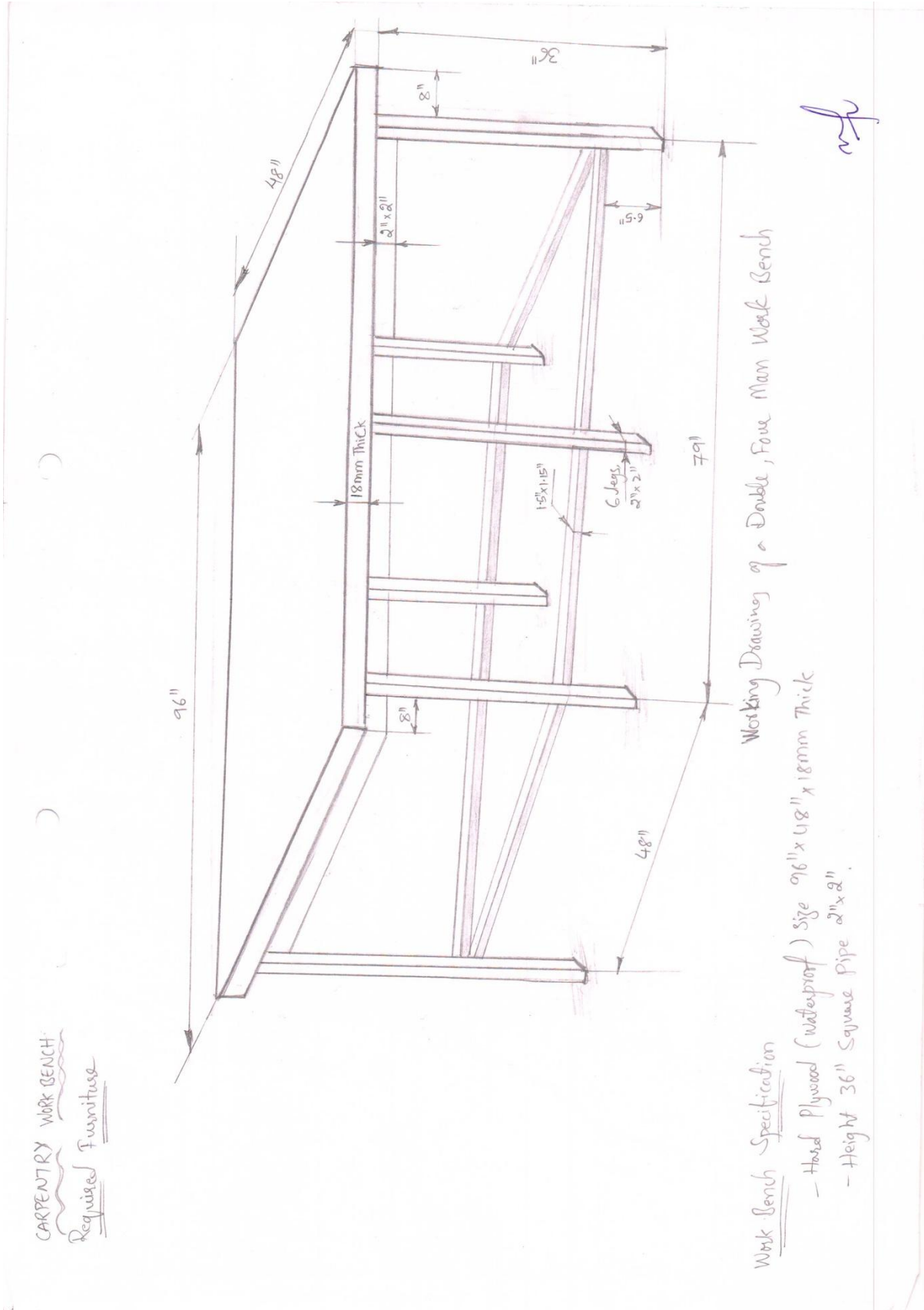

PURCHASE & STORES SECTION

